

PRODUCT FEATURES

CONSTRUCTION

- 7MM POLYPROPYLENE PLASTIC FLIGHT PANEL SHEET FOR WALL PANELING

NOTES:
UNLESS SPECIFIED IN THE DRAWING,
ALL PRODUCTS DISPLAYED IN THIS
DRAWING OTHER THAN THE PANELS
ITSELF IS NOT PART OF OUR PRODUCT
OFFERING.

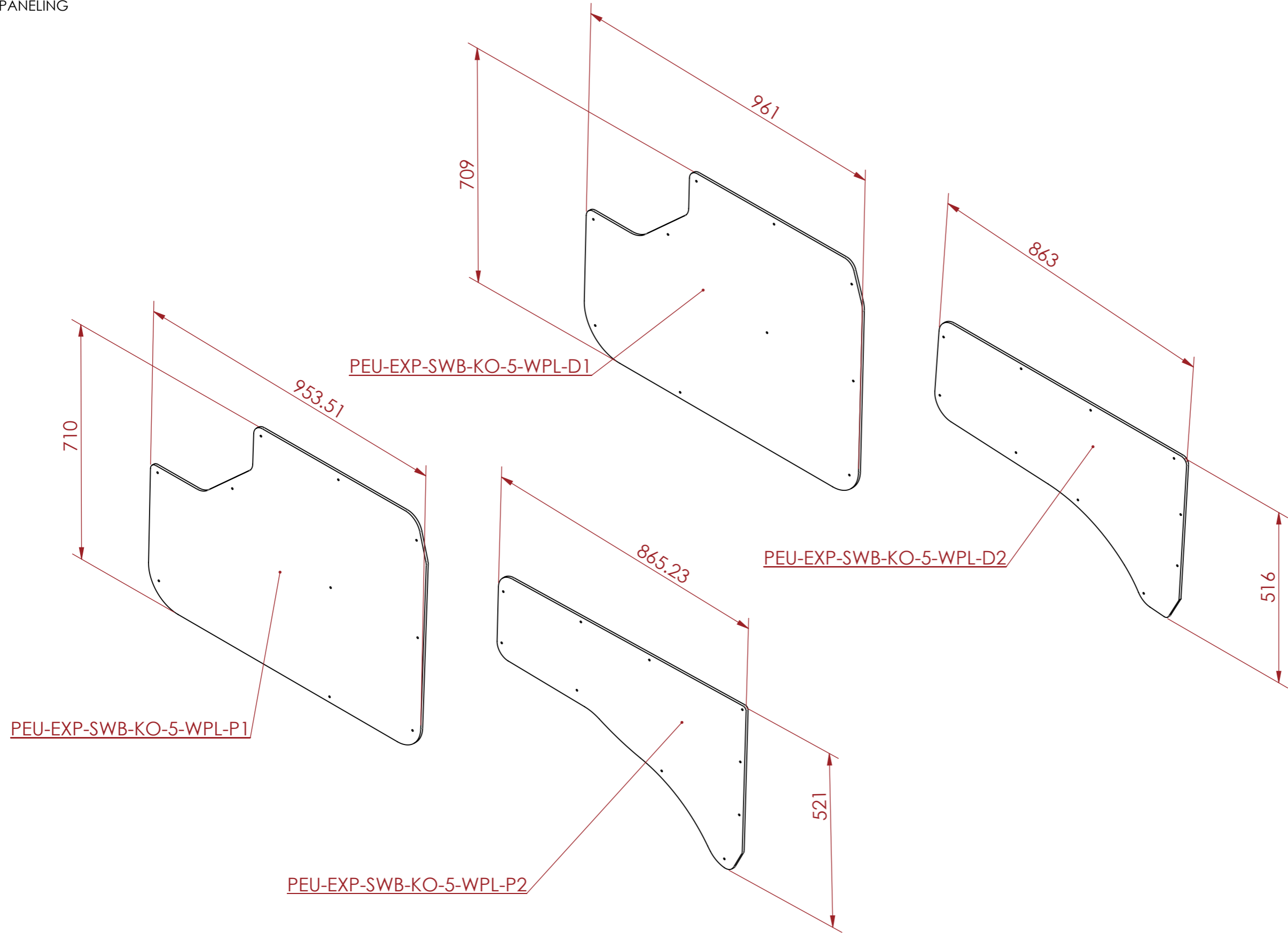

INSTALLATION COST

154.44 AUD

ESTIMATED WEIGHT:

4.65 KG

ITEM CODE:

PEU-EXP-SWB-KO-5-WPL

DRAWN BY:

KA

CHECKED BY:

AS

SCALE:

NTS



MAIL : sales@armorcases.com.au
WEB : www.armorcases.com.au